

- SITE SPECIFIC NOTES:**
1. THE OWNER OF THE PROPERTY IS SJ LAND & DEVELOPMENT LLC. THE SUBJECT PROPERTY IS WINDMILL PARK SUBDIVISION, BLOCK 1, LOTS 1 AND 2. PROPERTY IS ZONED PLANNED DEVELOPMENT - MIXED USE DISTRICT (PD-M) PER ORDINANCE NO. 2522.
 2. THE TOTAL DISTURBED AREA FOR THIS PROJECT IS 2.25 ACRES (97,904 SF).
 3. THE SUBJECT TRACT DOES NOT LIE WITHIN THE 100 YEAR FLOODPLAIN ACCORDING TO FEMA FLOOD INSURANCE RATE MAPS FOR BRAZOS COUNTY, TEXAS AND INCORPORATED AREAS, COMMUNITY NO. 480083, PANEL NO. 0185E, MAP NO. 4804100196E, EFFECTIVE DATE, MAY 18, 2012.
 4. THE MINIMUM REQUIRED FIRE FLOW FOR A PET RESORT BUILDING IBC TYPE VB OF 10,770 SF IS 2,750 GALLONS PER MINUTE. THE BUILDING IS SPRINKLERED WHICH REDUCES THE FIRE FLOW BY 50% (1380 GPM). TWO FIRE HYDRANTS ARE REQUIRED. THE EXISTING HYDRANTS WILL BE SUFFICIENT.
 5. PARKING LOT STRIPING OTHER THAN FIRE LANE STRIPING SHALL CONFORM TO TEXAS DEPARTMENT OF TRANSPORTATION (TDDOT) STANDARD SPECIFICATIONS FOR CONSTRUCTION OF HIGHWAYS, STREETS, AND BRIDGES, ITEM 606, TYPE 2 MARKING MATERIALS.
 6. CONTOURS SHOWN ARE FROM FIELD SURVEY DATA.
 7. THE OWNERSHIP AND MAINTENANCE RESPONSIBILITIES OF THE PRIVATE DRAINAGE EASEMENT WILL BE BY THE LOT OWNER OR PROPERTY OWNER ASSOCIATION.
 8. ALL STORM SEWER IS PRIVATE. STORM SEWER COVERS SHALL BE LABELED PRIVATE AND SHALL NOT USE THE CITY OF BRYAN LOGO ON COVERS.
 9. THE CONTRACTOR SHALL BE RESPONSIBLE FOR THE CONTAINMENT AND PROPER DISPOSAL OF ALL LIQUID AND SOLID WASTE ASSOCIATED WITH THE CONSTRUCTION OF THIS PROJECT. THE CONTRACTOR SHALL USE ALL MEANS NECESSARY TO PREVENT THE OCCURRENCE OF WIND BLOWN LITTER FROM THE PROJECT SITE.
 10. THE CONTRACTOR IS REQUIRED TO PROVIDE CONTAINMENT FOR WASTE PRIOR TO AND DURING DEMOLITION AND CONSTRUCTION. SOLID WASTE ROLL-OFF BINS/METAL DUMPSTERS SHALL BE SUPPLIED BY THE CITY OR CITY PERMITTED CONTRACTORS ONLY.
 11. NORMAL DOMESTIC WASTEWATER IS ANTICIPATED TO BE DISCHARGED FROM THIS DEVELOPMENT.
 12. ALL BACKFLOW DEVICES MUST BE INSTALLED AND TESTED UPON INSTALLATION AS PER CITY ORDINANCE.
 13. THE IRRIGATION SYSTEM MUST BE PROTECTED BY EITHER AN ATMOSPHERIC OR A PRESSURE VACUUM BREAKER OR REDUCED PRESSURE PRINCIPLE BACK FLOW DEVICE AND INSTALLED AS PER CITY ORDINANCE.
 14. 8" CONCRETE PAVEMENT TO BE PROVIDED FOR DUMPSTER LOCATIONS PER CITY OF BRYAN ORDINANCE. THE PAVEMENT SHALL BE REINFORCED WITH #5 BARS AT 12" O/C AND THE PAD SHALL EXTEND AN ADDITIONAL 10' IN FRONT OF CONTAINMENT AREA.
 15. FIRE SPRINKLER SYSTEM - POTABLE WATER SUPPLY MUST BE PROTECTED BY A TESTABLE DOUBLE CHECK VALVE ASSEMBLY AND INSTALL AS PER CITY ORDINANCE.
 16. ALL DEVICES, APPURTENANCES, APPLIANCES AND APPARATUS INTENDED TO SERVE SOME SPECIAL FUNCTION AND THAT CONNECTS TO THE WATER SUPPLY SYSTEM SHALL BE PROVIDED WITH PROTECTION AGAINST BACKFLOW AND CONTAMINATION OF THE WATER SUPPLY.
 17. REFER TO WINDMILL PARK SUBDIVISION PLAT FOR EASEMENT RECORD INFORMATION.
- GENERAL NOTES:**
1. ALL CONSTRUCTION SHALL BE IN ACCORDANCE WITH THE LATEST CITY OF BRYAN/COLLEGE STATION STANDARD SPECIFICATIONS AND DETAILS FOR WATER, SEWER, STREET, DRAINAGE. ALL CONSTRUCTION SHALL BE COORDINATED WITH THE CITY ENGINEER'S OFFICE.
 2. ALL UTILITY LINES (WATER, GAS, SANITARY SEWER, STORM SEWER, ETC.) SHOWN ARE TAKEN FROM BEST AVAILABLE RECORD INFORMATION BASED ON INDEPENDENT UTILITY MARKING DOCUMENTS OBTAINED FROM CITY & NEARBY AGENCIES AND/OR ABOVE GROUND FIELD EVIDENCE. SHOWN POSITIONS MAY NOT REPRESENT AS-BUILT CONDITIONS.
 3. THE CONTRACTOR SHALL BE RESPONSIBLE FOR VERIFYING THE EXACT LOCATION OF ALL EXISTING UNDERGROUND UTILITIES. NOTIFICATION OF THE UTILITY COMPANIES 48 HOURS IN ADVANCE OF CONSTRUCTION IS REQUIRED. DIG TESS: (800) 344-8377
ATMOS ENERGY: (979) 774-2508
SULZER LINK COMMUNICATIONS: (979) 299-2429
FRONTIER COMMUNICATIONS: (979) 821-4783
WATER/SEWER CITY OF BRYAN: (979) 209-5900
BTU: (979) 821-5700
(979) 209-5900
 4. THE CONTRACTOR SHALL SET UP A PRE-CONSTRUCTION MEETING WITH BTU PRIOR TO THE START OF ELECTRICAL INFRASTRUCTURE CONSTRUCTION.
 5. THE CONSTRUCTION SHALL COMPLY WITH GSA STANDARD 29 CFR PART 1926 SUBPART P FOR TRENCH SAFETY REQUIREMENTS.
 6. BUILDING SETBACK SHALL BE IN ACCORDANCE WITH THE CITY OF BRYAN CODE OF ORDINANCES.
 7. PROPOSED SIGNS SHALL BE PERMITTED SEPARATELY IN ACCORDANCE WITH THE SIGN ORDINANCE.
 8. IT IS THE RESPONSIBILITY OF THE CONTRACTOR TO USE WHATEVER MEANS NECESSARY TO MINIMIZE EROSION AND PREVENT SEDIMENT FROM LEAVING THE PROJECT SITE. THIS INCLUDES THE INSTALLATION OF CONSTRUCTION EXIT AND SILT FENCE AS NECESSARY.
 9. THE CONTRACTOR IS REQUIRED TO MAINTAIN THE TRADES GENERAL PERMIT NO. TAP 150000 REQUIREMENTS FOR ALL CONSTRUCTION SITES.
 10. ALL AREAS WHERE EXISTING VEGETATION AND GRASS COVER HAVE BEEN DISTURBED BY CONSTRUCTION SHALL BE ADEQUATELY BLOCK SODED OR HYDROMULCHED AND RESEEDING SHALL BE INSTALLED IN DEVELOPED AREAS WHERE GRASS IS PRESENT. BLOCK SOE WILL BE REQUIRED. BARED AREAS SHALL BE SEEDS OR SODED WITHIN 14 CALENDAR DAYS OF LAST DISTURBANCE.
 11. LANDSCAPING AND IRRIGATION DESIGN & ANALYSIS WILL BE PROVIDED ON THE LANDSCAPE & IRRIGATION PLANS. THE IRRIGATION SYSTEM MUST BE APPROVED AND INSTALLED PRIOR TO CERTIFICATE OF OCCUPANCY.
 12. ALL RADI AND DISTANCES ARE MEASURED TO THE BACK OF CURB UNLESS OTHERWISE NOTED.
 13. ALL PAVEMENT SHALL BE PER TYPICAL PAVEMENT SECTION. REFER TO PAVEMENT PLAN FOR EASEMENT STRIPING.
 14. DETENTION AND DRAINAGE FACILITIES SHALL ARE EXISTING.
 15. THE CONTRACTOR SHALL PROMPTLY NOTIFY THE ENGINEER OF ANY DISCREPANCIES IN THESE PLANS, DRAWINGS AND SPECIFICATIONS.
 16. IT IS THE RESPONSIBILITY OF THE CONTRACTOR TO COMPLY WITH ALL STATE AND FEDERAL REGULATIONS REGARDING CONSTRUCTION ACTIVITIES NEAR ENERGIZED OVERHEAD POWER LINES.
 17. THE CONTRACTOR SHALL BE RESPONSIBLE FOR THE PROTECTION OF ALL EXISTING UTILITIES OR SERVICE LINES THAT ARE CROSSED OR EXPOSED DURING CONSTRUCTION OPERATIONS. WHERE EXISTING UTILITIES OR SERVICE LINES ARE CUT, BROKEN, OR DAMAGED, THE CONTRACTOR SHALL REPAIR OR REPLACE THE UTILITIES OR SERVICE LINES WITH THE SAME TYPE OF MATERIAL AND CONSTRUCTION OR BETTER. THIS MATERIAL AND WORK SHALL BE AT THE CONTRACTOR'S OWN RISK AND EXPENSE.
 18. A COPY OF THE APPROVED CONSTRUCTION PLANS MUST BE KEPT ON SITE AT ALL TIMES THROUGHOUT THE ENTIRE CONSTRUCTION OF THE PROJECT. CONTRACTOR SHALL MAINTAIN A SET OF RECORD DRAWINGS, RECORDING AS-BUILT CONDITIONS DURING CONSTRUCTION.
 19. ANY ADJACENT PROPERTY AND RIGHT-OF-WAY DISTURBED DURING CONSTRUCTION WILL BE RETURNED TO THEIR EXISTING CONDITION OR BETTER.
 20. THE CONTRACTOR SHALL NOT CREATE A DIRT NUISANCE OR SAFETY HAZARD IN ANY STREET OR DRIVEWAY.
 21. ADEQUATE DRAINAGE SHALL BE MAINTAINED AT ALL TIMES DURING CONSTRUCTION AND ANY DRAINAGE DITCH OR STRUCTURE DISTURBED DURING CONSTRUCTION SHALL BE RESTORED TO EXISTING CONDITIONS OR BETTER.
 22. THE CONTRACTOR SHALL PROTECT ALL MONUMENTS, IRON PINS, AND PROPERTY CORNERS DURING CONSTRUCTION.
 23. THE IRRIGATION SYSTEM WILL BE PROTECTED BY EITHER A PRESSURE VACUUM BREAKER, A REDUCED PRESSURE PRINCIPLE BACK FLOW DEVICE, OR A DOUBLE-CHECK BACK FLOW DEVICE, AN INSTALLED AS PER CITY ORDINANCE 2394.
 24. ALL BACK FLOW DEVICES WILL BE INSTALLED AND TESTED UPON INSTALLATION.
 25. THE CONTRACTOR MAY OBTAIN AN ELECTRONIC COPY OF THESE PLANS FOR CONSTRUCTION PURPOSES. THE ELECTRONIC FILE AND INFORMATION GENERATED, BY SCHULTZ ENGINEERING, LLC (SE), FOR THIS PROJECT IS CONSIDERED BY SE TO BE CONFIDENTIAL. WHEN ISSUED, ITS USE IS INTENDED SOLELY FOR THE INDIVIDUAL OR ENTITY TO WHICH IT IS ADDRESSED. PERMISSION IS NOT GRANTED TO THE RECIPIENT FOR DISTRIBUTION OF THE INFORMATION IN ANY FORM OR MANNER. THE RECIPIENT UNDERSTANDS THAT THIS DATA IS AUTHORIZED "AS IS" WITHOUT ANY WARRANTY AS TO ITS ACCURACY, FREEDOM FROM ERROR, OR AS TO ANY RESULTS GENERATED THROUGHOUT ITS USE. THE RECIPIENT ALSO UNDERSTANDS AND AGREES UPON ACCEPTANCE OF SUCH DATA IS NO LONGER RESPONSIBLE FOR THEIR USE OR MODIFICATION. THE USER AND THE RECIPIENT OF THE ELECTRONIC DATA ACCEPTS FULL RESPONSIBILITY AND LIABILITY FOR ANY CONSEQUENCES ARISING OUT OF THEIR USE.
 26. WHERE ELECTRIC FACILITIES ARE INSTALLED, BTU HAS THE RIGHT TO INSTALL, OPERATE, RELocate, RECONSTRUCT, ADD TO, MAINTAIN, INSPECT, PATROL, ENLARGE, REPAIR, REMOVE, AND REPLACE SAID FACILITIES UPON, OVER, UNDER, AND ACROSS THE PROPERTY INCLUDED IN THE PUE, AND THE RIGHT OF INSPECTION AND ACCESS ON PROPERTY ADJACENT TO THE PUE TO ACCESS ELECTRIC FACILITIES.

BENCHMARK INFORMATION

BM	N	E	ELEV
BTM 1	N: 1022092.06	E: 353555.18	ELEV: 330.63'
	5/8" INCH IRON ROD SET ON SOUTHWEST SIDE OF HARVEY MITCHELL		
BTM 2	N: 1022148.70	E: 3353180.31	ELEV: 329.26'
	5/8" INCH IRON ROD SET ON NORTHEAST SIDE OF HARVEY MITCHELL		
BTM 3	N: 1022171.74	E: 3534886.97	ELEV: 336.97'
	5/8" INCH IRON ROD SET ON NORTHEAST SIDE OF HARVEY MITCHELL		

Curve Table

CURVE #	LENGTH	RADIUS	DELTA	TANGENT	CHORD	CHORD DIRECTION
C1	108.38'	268.70'	02°30'36"	54.94'	107.65'	S30°46'11"W

LEGEND

- PROPOSED CONTOUR
- EXISTING CONTOUR
- PROPERTY BOUNDARY
- ADJACENT PROPERTY BOUNDARY
- RIGHT OF WAY (ROW)
- LOT LINE
- PROPERTY SETBACK
- PROPOSED PUBLIC UTILITY EASEMENT (PUE)
- EXISTING PUBLIC UTILITY EASEMENT (PUE)
- PROPOSED PUBLIC ACCESS EASEMENT (PAE)
- EXISTING PUBLIC ACCESS EASEMENT (PAE)
- PROPOSED PRIVATE ACCESS EASEMENT (PRAE)
- EXISTING PRIVATE ACCESS EASEMENT (PRAE)
- PROPOSED PUBLIC DRAINAGE EASEMENT (PDE)
- EXISTING PUBLIC DRAINAGE EASEMENT (PDE)
- PROPOSED PRIVATE DRAINAGE EASEMENT (PRDE)
- EXISTING PRIVATE DRAINAGE EASEMENT (PRDE)
- LIMITS OF DISTURBANCE
- FIRE LANE
- PROPOSED CURB AND GUTTER
- EXISTING CURB AND GUTTER
- FLOW ARROWS
- ST --- ST --- STORM PIPE
- W-B --- PROPOSED WATERLINE, SIZE NOTED
- W-B --- EXISTING WATERLINE, SIZE NOTED
- S-B --- PROPOSED SANITARY SEWER LINE, SIZE NOTED
- S-B --- EXISTING SANITARY SEWER LINE, SIZE NOTED
- GAS --- PROPOSED GAS LINE, SIZE NOTED
- GAS --- EXISTING GAS LINE, SIZE NOTED
- UE --- PROPOSED UNDERGROUND ELECTRIC LINE
- UE --- EXISTING UNDERGROUND ELECTRIC LINE
- E --- EXISTING OVERHEAD ELECTRIC LINE

VICINITY MAP



WEST BRAZOS ANIMAL CLINIC
1224 AND 1212 BAGGS COURT

TOTAL DISTURBED AREA = 2.25 ACRES
WINDMILL PARK SUBDIVISION
BLOCK 1, LOTS 1 AND 2
TOTAL AREA = 3.505
VOL. ###, PG. ###
ZENO PHILLIPS LEAGUE, A - 45
BRYAN, BRAZOS COUNTY, TEXAS

SCALE: 1"=30'
SEPTEMBER 2023
OWNER/DEVELOPER: SJ LAND & DEVELOPMENT LLC
SURVEYOR: BRAD KERR, RPLS NO. 4502
ENGINEER: SCHULTZ ENGINEERING, LLC

UTILITY DEMAND
WATER DEMAND, PET RESORT

AVERAGE	16 GPM
MAXIMUM (PEAK)	64 GPM
1.5" DOMESTIC WATER METER	
AVERAGE	5.75 GPM
MAXIMUM (PEAK)	23 GPM
4" SANITARY SEWER LINE	
① 1.04 % MIN. SLOPE	
FIXTURE UNITS = 45	
PIPE SLOPE OK	

UTILITY DEMAND
WATER DEMAND, CLINIC

AVERAGE	16 GPM
MAXIMUM (PEAK)	64 GPM
1.5" DOMESTIC WATER METER	
AVERAGE	7.5 GPM
MAXIMUM (PEAK)	30 GPM
4" SANITARY SEWER LINE	
① 1.04 % MIN. SLOPE	
FIXTURE UNITS = 60	
PIPE SLOPE OK	

PARKING ANALYSIS

REQUIRED PARKING

9270 SF OF VETERINARY CLINIC
1 SPACE PER 300 SF
31 SPACES REQUIRED

840 SF OF CLINIC KENNELS NO PARKING REQUIRED

6599 SF OF PET RESORT FACILITY
1 SPACE PER 300 SF
22 SPACES REQUIRED

4,171 SF OF BOARDING KENNELS NO PARKING REQUIRED

TOTAL REQUIRED: 53 SPACES
9' WIDTH, 20' LENGTH TYP.

PROPOSED PARKING

60 SPACES PARKING
3 SPACES ACCESSIBLE PARKING
63 SPACES PROVIDED

MARK	REVISION	BY	DATE

SURVEYED	DESIGNED	DRAWN	APPROVED	JOB NO.	DATE
KERR	DLD	DLD	JPS	21-944	SEPTEMBER 2023

THIS DOCUMENT IS RELEASED FOR THE PURPOSE OF REVIEW ONLY UNDER THE AUTHORITY OF DEVEN L. DOYEN P.E., LICENSE NO. 109835, ON SEPTEMBER 20, 2023. IT IS NOT TO BE USED FOR BIDDING OR CONSTRUCTION PURPOSES.

WEST BRAZOS ANIMAL CENTER
WINDMILL PARK SUBDIVISION
LOT 1-5, BLOCK 18 - BRYAN, TX

SITE PLAN

SCALE: VERTICAL N/A, HORIZONTAL 1"=30'

PLOTTING SCALE: 1:1

FILE NAME: 21-944

SHEET: **C1**



SCHULTZ Engineering, LLC
911 Southwest Pkwy E.
College Station, Texas 77840
979.764.3900
TBP FIRM NO. 12327

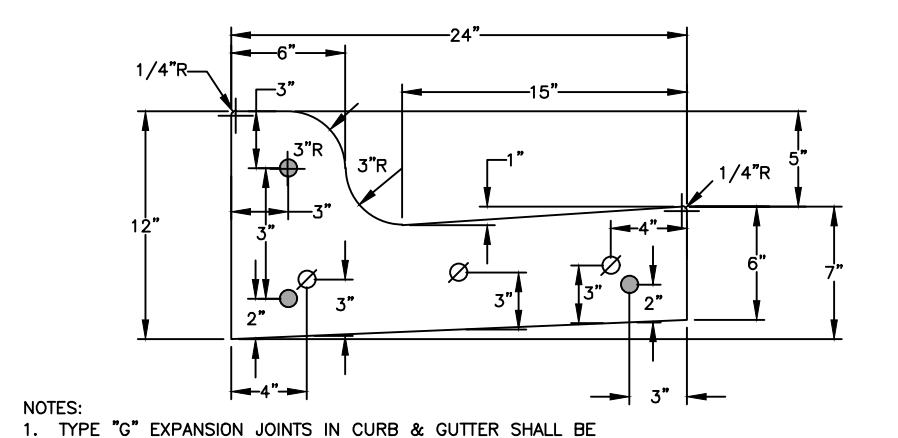

COMBINED CURB AND GUTTER SECTION DETAIL - TYPICAL
N.T.S.

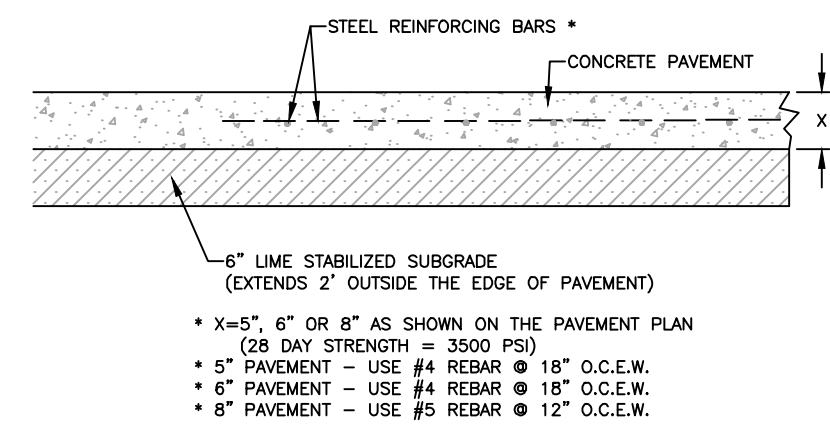

CONCRETE PAVING SECTION DETAIL - TYPICAL
N.T.S.

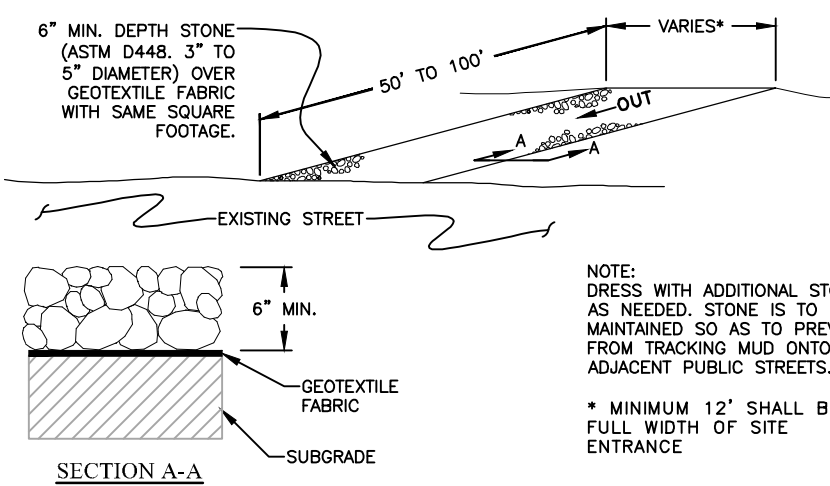

CONSTRUCTION EXIT SILT CONTROL DETAIL
N.T.S.

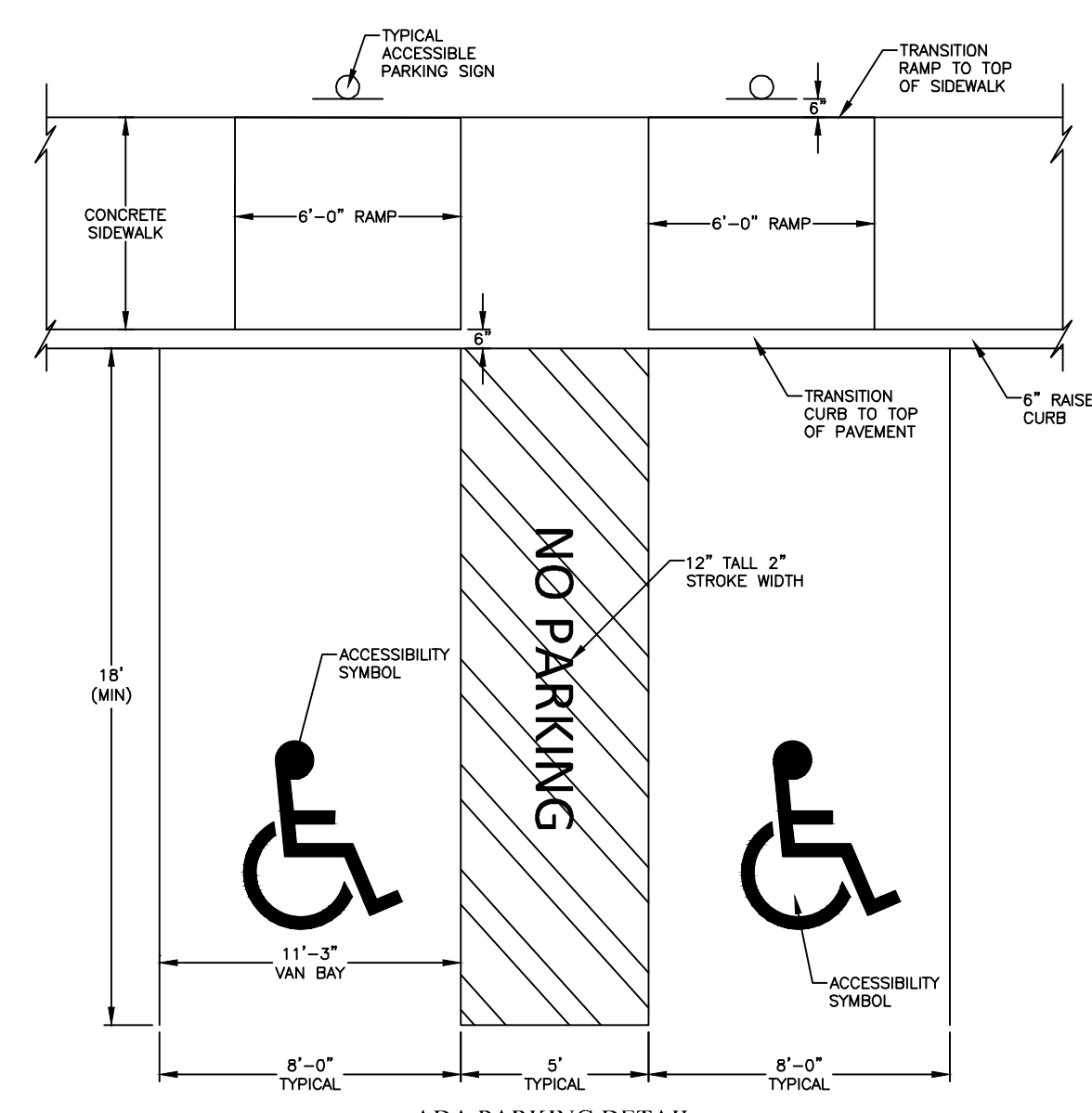

ADA PARKING DETAIL
N.T.S.

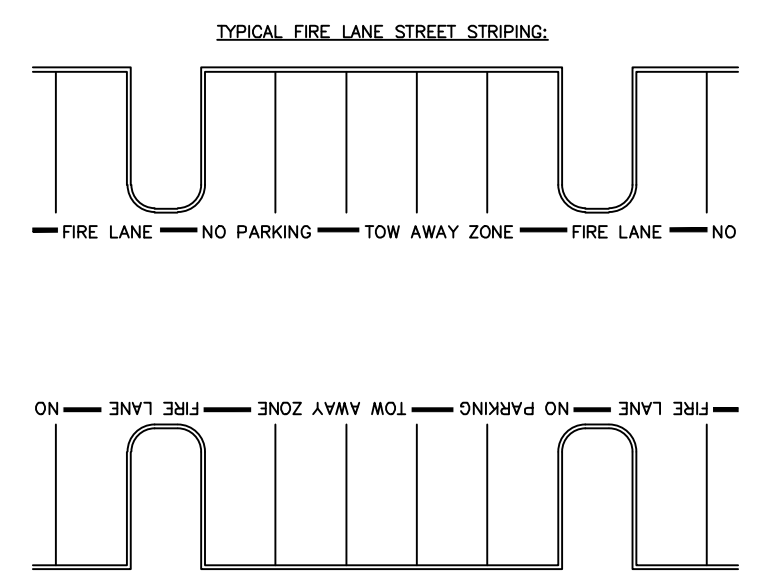

FIRE LANE STRIPING AND SIGNAGE DETAIL
N.T.S.

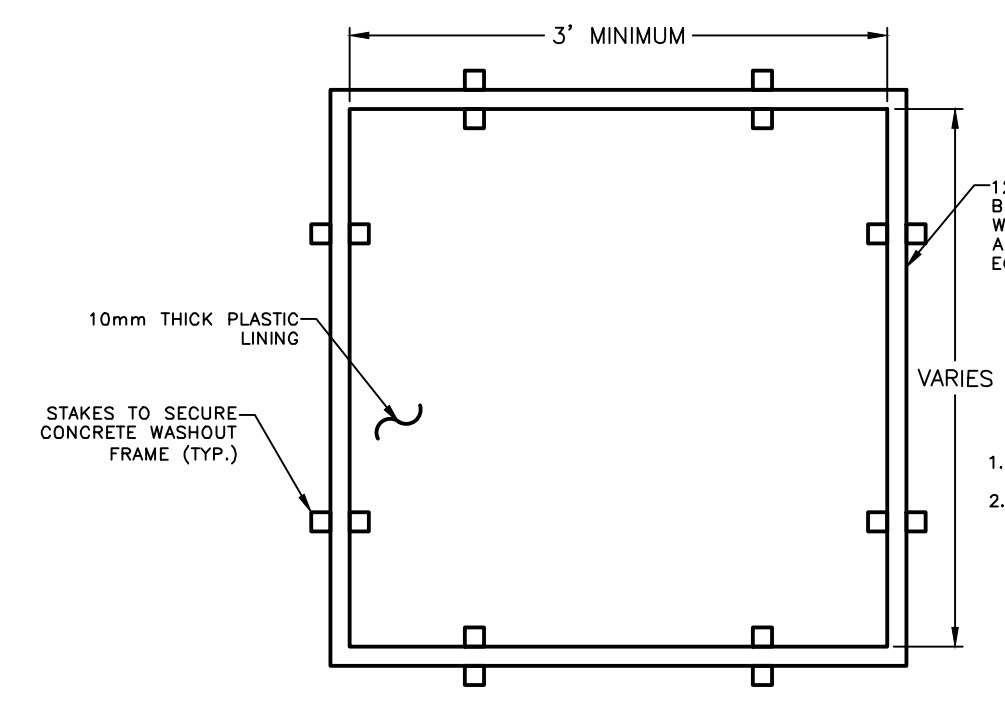

CONCRETE WASHOUT DETAIL
N.T.S.

- FIRE LANE MARKING NOTES:**
- SIGN SHALL COMPLY WITH THE CITY FIRE SERVICE STANDARDS.
 - ALL CURBS AND CURB ENDS SHALL BE PAINTED RED WITH FOUR INCH (4") WHITE LETTERING STATING "FIRE LANE - NO PARKING - TOW AWAY ZONE". WORDING MAY NOT BE SPACED MORE THAN FIFTEEN FEET APART.
 - A SIGN TWELVE INCHES (12") WIDE AND EIGHTEEN INCHES (18") IN HEIGHT SHALL BE MOUNTED IN A CONSPICUOUS LOCATION AT EACH ENTRANCE TO THE PROPERTY AND AT THE LOCATIONS SHOWN. SUCH SIGNS SHALL BE TWELVE INCHES (12") WIDE AND EIGHTEEN INCHES HIGH, WITH A COMPANION SIGN TWELVE INCHES (12") WIDE AND SIX INCHES (6") HIGH STATING "TOW-AWAY ZONE". SUCH SIGNS SHALL BE PAINTED ON A WHITE BACKGROUND WITH SYMBOLS, LETTER AND BORDER IN RED.
 - FROM THE POINT THE FIRE LANE BEGINS TO THE POINT THE FIRE LANE ENDS, INCLUDING BEHIND ALL PARKING SPACES, SHALL BE MARKED WITH ONE CONTINUOUS EIGHT INCH (8") RED STRIPE PAINTED ON THE DRIVE SURFACE BEHIND THE PARKING SPACES. ALL CURBS ADJOINING A FIRE LANE MUST BE PAINTED RED. RED STRIPES AND CURBS WILL CONTAIN THE WORDING "FIRE LANE-NO PARKING-TOW AWAY ZONE", PAINTED IN FOUR INCH (4") WHITE LETTERS. (FIGURE "A" IN ORDINANCE NO. 1630 ILLUSTRATES STRIPING ON DRIVE SURFACE BEHIND PARKING SPACES.)
 - TOW-AWAY ZONE SIGN SHALL BE 12" WIDE X 6" TALL PER TMUTCO R7-2016P SIGNAGE.

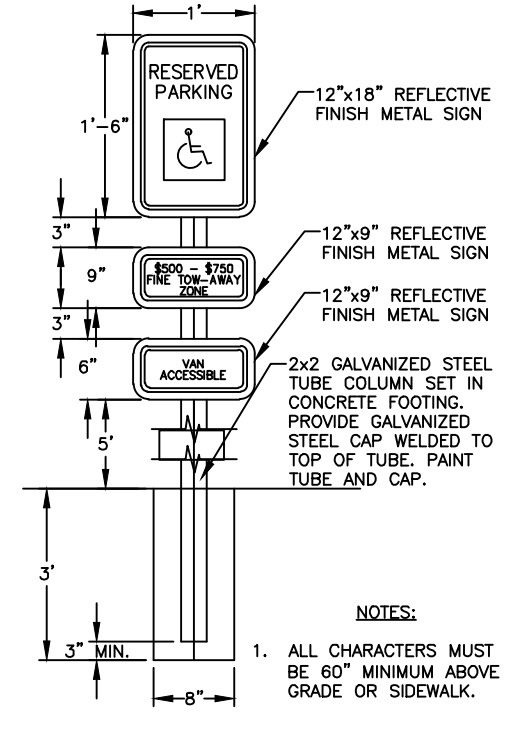

ADA SIGN DETAIL
N.T.S.



911 Southwest Pkwy E.
College Station, Texas 77840
979.764.3900
TBPE FIRM NO. 12327

SURVEYED	DESIGNED	DRAWN	APPROVED	JOB NO.	DATE
KERR	DLD	DLD	JPS	21-944	SEPTEMBER 2023

THIS DOCUMENT IS RELEASED FOR THE PURPOSE OF REVIEW ONLY UNDER THE AUTHORITY OF DEVEN L. DOYEN P.E., LICENSE NO. 109835, ON SEPTEMBER 20, 2023. IT IS NOT TO BE USED FOR BIDDING OR CONSTRUCTION PURPOSES.

WEST BRAZOS ANIMAL CENTER
WINDMILL PARK SUBDIVISION
LOT 1-5, BLOCK 18 - BRYAN, TX

SITE PLAN DETAILS

SCALE	N/A
VERTICAL	1"=30'
HORIZONTAL	1"=30'
PLOTTING SCALE:	1:1
FILE NAME:	21-944

SHEET
C2